

KAP Series Differential Pressure Transducer



bf1systems

The Competitive Advantage

The KAP Series is designed for the measurement of dynamic air/gas pressure on or within a vehicle. When used with a Pitot Tube the transducer measures the differential air pressure which is proportional to air speed. Alternatively the KAP can be connected to pressure tapings on aero surfaces to evaluate aerodynamic performance. These transducers are suitable for use directly onto vehicles or as part of a test stand or dyno. Offering a high level of reliability and endurance, the KAP is protected against the high vibration, shock and high temperatures found in motorsport. Also suitable for wet/wet installations.

With a modular construction and programmable amplifier, this provides a fast delivery time for standard configurations. Pressure ranges are available between 25 to 75 mBar Differential. Industry standard 3-wire electrical connections allow configuration with most common ECU's and data logging systems.

The KAP Series is race proven and can be found in many race series around the world. Please see our separate datasheet (KAPT) for details of the standard and custom Pitot Tubes that can be supplied.

Technical Specifications

Pressure Reference	Differential
Standard Pressure Ranges (mBar)	25, 50 & 75
Safe Over Range	300% of Range
Burst Pressure	1000% of Range
Accuracy	±0.5% FS Combined Linearity & Hysteresis (CNLH)
Thermal Accuracy	Zero ±0.02% FS/°C (Sensitivity ±0.02% of Reading /°C)
Output	0.5V to 4.5V (±0.5%)
Supply	5V (±0.5V) Ratiometric or 8-16Vdc
Operating Temperature Range	-40°C to +125°C
Compensated Temperature Range	0°C to +125°
Construction	Anodised Aluminium and Stainless Steel
Electrical Connection	100cm 26AWG, 55Spec Wire + DR25 Sleeve
Process Connection	Barb Fitting (To Suit 2mm ID Tube)
Protection Class	IP67. Dust tight & water immersion to 1m for 30mins
EMC Protection & Vibration	EN E50082-1 and Mil-Std-810C, Curve L, 20G
Weight	Sensor: 30g, Pitot Tube: 60g

bf1systems adopts a continuous development program which sometimes necessitates specification changes without notice.

Features

- Miniature Size
- 5V or 8-16V Supply
- 25 to 75 mBar Range
- Rugged Design
- Amplified Output

Applications

- Aerodynamics
- Air Speed

Contact Us:

bf1systems
Unit 13 Springfield Business
Park
Priest Court
Grantham
Lincolnshire
NG31 7FZ
United Kingdom

+44 (0)1476 568057
sales@bf1systems.com

Part Number Configuration

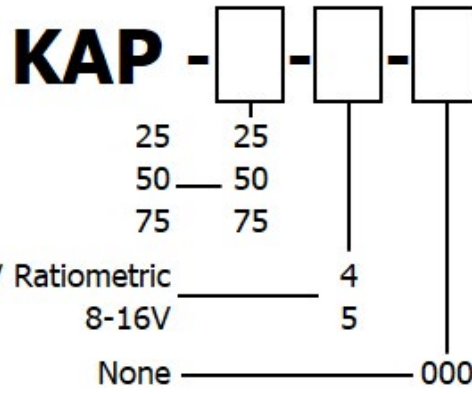

Pressure Range (mBar)

Supply Voltage

Special Codes

Mechanical Details

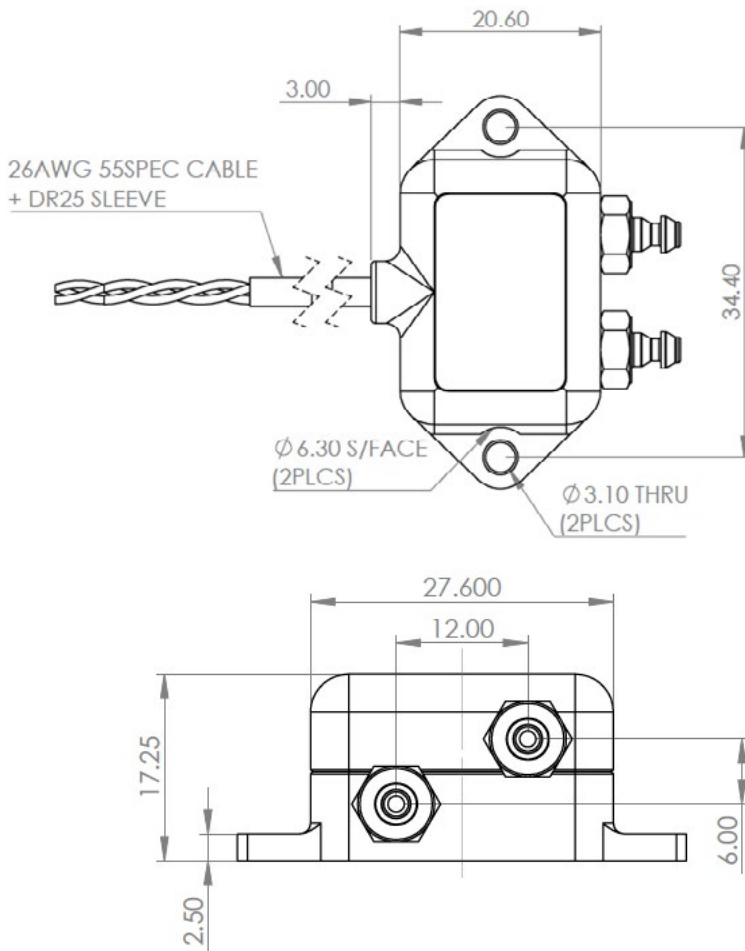

Connection Details

+VE Supply	0V Supply	Signal
Red	Black	White

bf1systems

The Competitive Advantage

Features

- Miniature Size
- 5V or 8-16V Supply
- 25 to 75 mBar Range
- Rugged Design
- Amplified Output

Applications

- Aerodynamics
- Air Speed

Contact Us:

bf1systems
 Unit 13 Springfield Business
 Park
 Priest Court
 Grantham
 Lincolnshire
 NG31 7FZ
 United Kingdom

+44 (0)1476 568057
 sales@bf1systems.com