

## NPT Series NPT1 Fluid Temperature Sensor



The NPT1 Series of High Performance Temperature Sensors are designed to measure the temperatures of fluid in demanding motorsport and automotive testing applications.

The sensing element can be either a PT1000 or a NTC 3KΩ Thermistor; calibration of each is well defined and can be installed into most common ECUs and data logging systems.

Construction in either brass or stainless steel with standard motorsports cable and sleeve will protect from the harsh environments around the vehicle.

The NPT1 Series are race proven in many formulae around the world and offer a reliable and robust solution for professional engineers.

### Technical Specifications

<b>Ranges (FS)</b>	-30°C to +150°C
<b>Accuracy</b>	<±1°C
<b>Response Time</b>	<10 Seconds
<b>Sensor Time</b>	NTC 3KΩ or PT1000
<b>Construction</b>	Brass or Stainless Steel
<b>Electrical Connection</b>	100cm, 26AWG 55 Spec wire + DR25 Sleeve
<b>Mechanical Connection</b>	1/8 Inch NPT Male (ANSI B1.20.1)
<b>Protection Class</b>	IP67
<b>Weight (Excluding Cable)</b>	Brass: 20g Stainless Steel: 20g

bf1systems adopts a continuous development program which sometimes necessitates specification changes without notice.

	NTC 10KΩ	PT1000
Temp °C	Output Ω	Output Ω
-30	53100.00	882.20
-20	29121.00	921.60
-10	16599.00	960.90
-0	9795.00	1000.00
10	5970.00	1039.00
20	3747.00	1077.90
25	3000.00	1097.30
30	2417.10	1116.70
40	1598.10	1155.40
50	1080.90	1194.00
60	746.40	1232.40
70	525.60	1270.80
80	376.50	1309.00
90	274.59	1347.10
100	203.46	1385.10
110	153.09	1422.90
120	116.79	1460.70
130	90.28	1498.30
140	70.58	1535.80
150	55.79	1573.30

### Features

- 1/8" NPT Thread
- Miniature Size
- -30°C to +150°C
- PT1000 or NTC
- Rugged Construction

### Applications

- Coolant
- Water
- Brake
- Fuel
- Oil

### Contact Us:

bf1systems  
Unit 13 Springfield Business  
Park  
Priest Court  
Grantham  
Lincolnshire  
NG31 7FZ  
United Kingdom

+44 (0)1476 568057  
sales@bf1systems.com

## Part Number Configuration

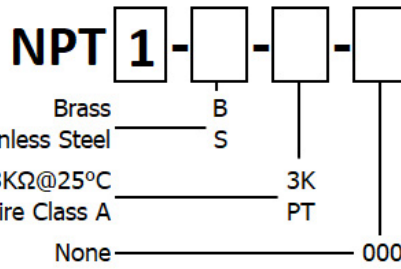

**Construction**

**Sensor Type**

**Special Code**

## Mechanical Details

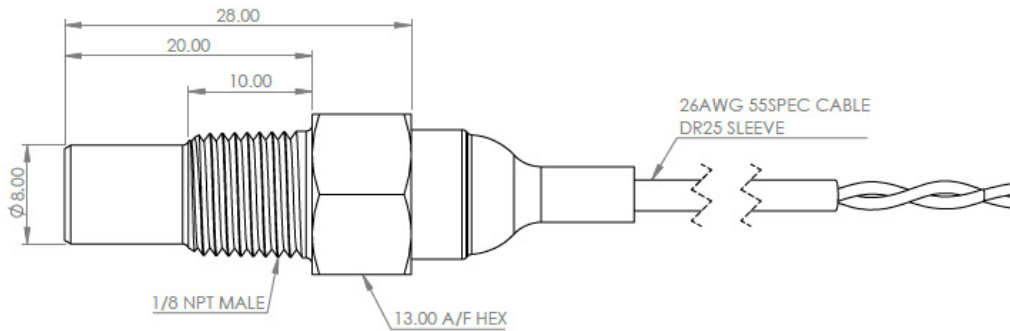

## NTC 3K $\Omega$ / PT1000 Temperature Graphs

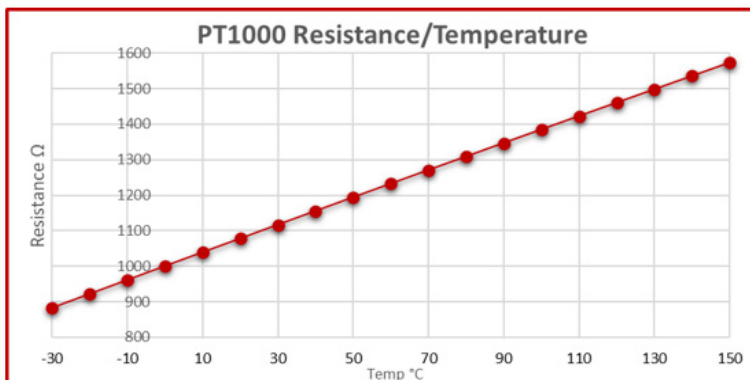
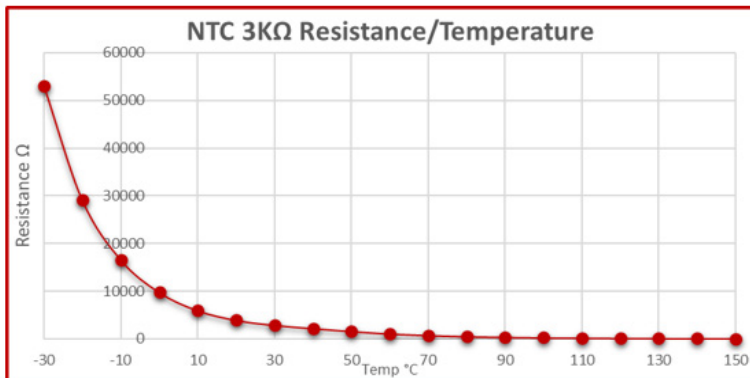

## Connection Details

Output	Output
Red	White

**bf1systems**

The Competitive Advantage

## Features

- 1/8" NPT Thread
- Miniature Size
- -30 $^{\circ}$ C to +150 $^{\circ}$ C
- PT1000 or NTC
- Rugged Construct

## Applications

- Coolant
- Water
- Brake
- Fuel
- Oil

## Contact Us:

bf1systems  
 Unit 13 Springfield Business  
 Park  
 Priest Court  
 Grantham  
 Lincolnshire  
 NG31 7FZ  
 United Kingdom

+44 (0)1476 568057  
 sales@bf1systems.com