

NTC Series NTC2F-Fast Response Air and Gas Temperature Sensor



The NTC2 Series of High Performance Temperature Sensors are designed to measure the temperatures of air and gas inlet on demanding motorsport and automotive testing applications.

The sensing element is a sub-miniature 10KΩ NTC Thermistor, with a very fast response time which helps to improve engine performance. Calibration of each is well defined and can be installed into most common ECUs and data logging systems.

Construction choice is either anodised aluminium, brass or stainless steel — all with a heat insulating PEEK ISOTIP which isolates the sensing element from surrounding heat soak. With standard motorsports cable and sleeve this will protect from the harsh environments around the vehicle.

Technical Specifications

Ranges (FS)	-30°C to +200°C
Accuracy	±1°C
Response Time	<2 Seconds (In Moving Air)
Sensor Time	NTC 10KΩ
Construction	Brass, Aluminium or Stainless Steel with PEEK ISOTIP
Electrical Connection	100cm, 26AWG 55M Spec wire + Viton Sleeve
Mechanical Connection	See Part Number Configurator
Protection Class	IP67
Weight (Excluding Cable)	5g to 10g

bf1systems adopts a continuous development program which sometimes necessitates specification changes without notice.

Temp °C	Output Ω
-30	120370.00
-20	71668.00
-10	44087.00
0	27936.00
10	18187.00
20	12136.00
25	10000.00
30	8284.50
40	5774.20
50	4102.60
60	2967.30
70	2181.70
80	1628.80
90	1233.50
100	946.59
110	735.47
120	578.10
130	459.36
140	368.75
150	298.86
160	244.40
170	201.60
180	167.60
190	140.40
200	118.50

Features

- Fast Response
- With PEEK ISOTIP
- -30°C to +200°C
- 10KΩ NTC
- Rugged Construction

Applications

- Air Intake
- Turbo Temperature

Contact Us:

bf1systems
Unit 13 Springfield Business
Park
Priest Court
Grantham
Lincolnshire
NG31 7FZ
United Kingdom

+44 (0)1476 568057
sales@bf1systems.com

Part Number Configuration

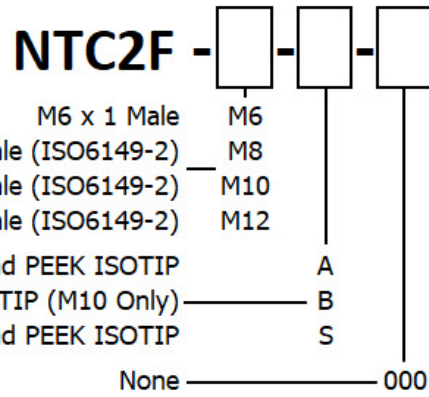

Mounting Thread

Construction

Special Code

Mechanical Details

M6 Thread

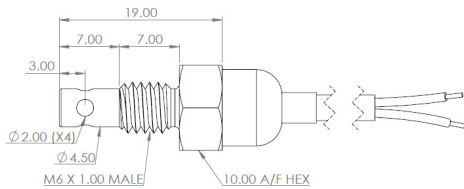

M8 Thread

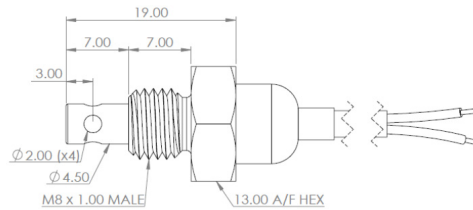

M10 Thread

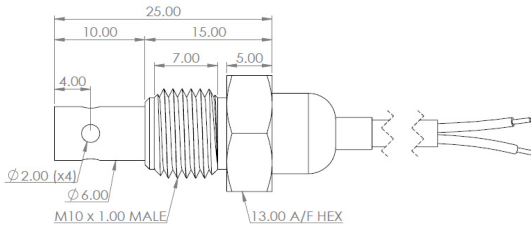

M12 Thread

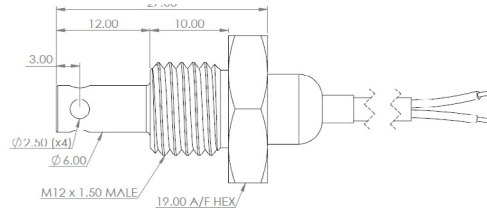

Maximum Torque Rating

Thread	Material	Max. Torque (Nm)
M6	Aluminium	1.5
	Stainless Steel	5
M8	Aluminium	8
	Stainless Steel	10
M10	Aluminium	10
	Brass	10
	Stainless Steel	15
M12	Aluminium	10
	Stainless Steel	15

bf1systems

The Competitive Advantage

Features

- Fast Response
- With PEEK ISOTIP
- -30°C to +200°C
- 10KΩ NTC
- Rugged Construction

Applications

- Air Intake
- Turbo Temperature

Contact Us:

bf1systems
 Unit 13 Springfield Business
 Park
 Priest Court
 Grantham
 Lincolnshire
 NG31 7FZ
 United Kingdom

+44 (0)1476 568057
 sales@bf1systems.com

NTC 10KΩ Temperature Graph

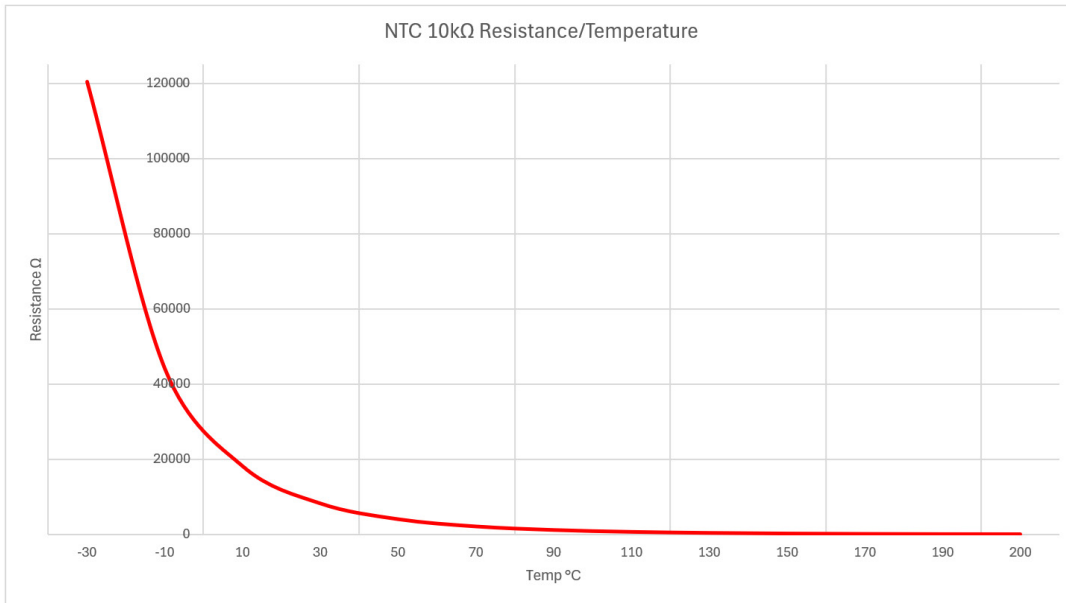

Features

- Fast Response
- With PEEK ISOTIP
- -30°C to +200°C
- 10KΩ NTC
- Rugged Construction

Connection Details

Output	Output
Red	White

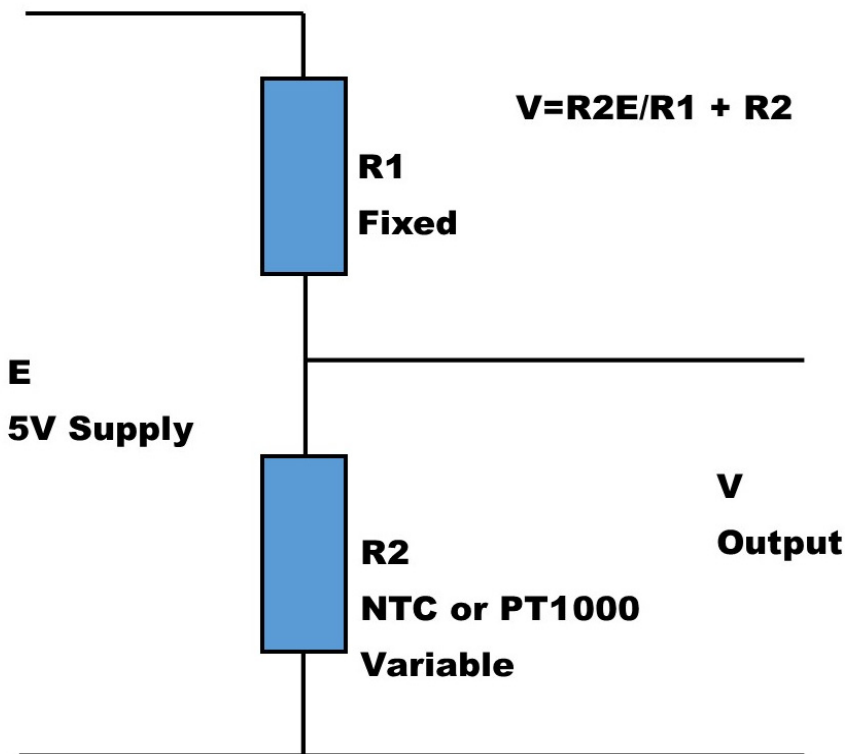

Applications

- Air Intake
- Turbo Temperature

Contact Us:

bf1systems
 Unit 13 Springfield Business
 Park
 Priest Court
 Grantham
 Lincolnshire
 NG31 7FZ
 United Kingdom

+44 (0)1476 568057
 sales@bf1systems.com