



RHL5 LASER RIDE HEIGHT SENSOR

The RHL5 Laser Ride Height Sensor builds on the success of its predecessor, offering class leading accuracy and reliability in a small, rugged package, but now also including the ability to dynamically configure the sensor via its CAN interface. Measurement rate, averaging filters and error handling can be adjusted on the fly, allowing the sensor configuration to be modified whilst fitted to the vehicle, ensuring the optimum signal is available under all running conditions.

The sensor incorporates a visible laser that is reflected off the track surface to a precision CCD detector which determines the height from the ground with a high degree of accuracy, whilst the on-board compensation ensures that different track colours and surfaces are correctly measured without error.

Supplied with either measurement ranges of 200mm or 500mm, the RHL5 is ideal for use on all types of vehicle. A user replaceable lens means that the part can be easily serviced in the field if required by the customer.

Features

- 200 & 500mm Range
- Dynamically Configurable By Customer
- Up To 4KHz Measurement Rate
- Customer Replaceable Lens

TECHNICAL SPECIFICATIONS

Measuring Range	200mm	500mm
Accuracy	±0.1%/FS	±0.2%/FS
Resolution	0.02mm	
Measurement Rate	250 - 4000Hz, 1000Hz (Default), Configurable via CAN	
Output	1 to 5Vdc	
CAN Operation	See 'CAN Configuration' Table	
Ambient Light	<10,000Lx	
Voltage Supply	11-30Vdc	
Current Draw	50mA (Typical)	
Insulation Resistance	>100MΩ at 100Vdc all cable terminations to housing	
Operating Temperature	0°C to +70°C	
Storage Temperature	-20°C to +70°C	
Construction	Housing: Black Anodised Aluminium	
	Lens: Plastic (Replaceable)	
Electrical Connection	100cm, 24AWG, 55spec Wire + DR25 Sleeve	
Ingress Protection	IP6K7	
Laser Type	1mW, 670nm, Class 2 (DIN EN 60825-1 2009)	
Vibration	20G 10Hz-1kHz & 15G 6ms (IEC 68-2-29)	
Weight	52g (Excluding Cable)	

Applications

- Ride Height
- Suspension Setup
- Chassis Distortion
- Bodywork Deflection

PART NUMBER CONFIGURATOR

RHL5 -

Measurement Range

200mm
500mm

200
500

Special Code

None — 000

The ka configuration tool is used to specify a standard ka sensor, other options are available on request.

MECHANICAL DETAILS

All dimensions in mm

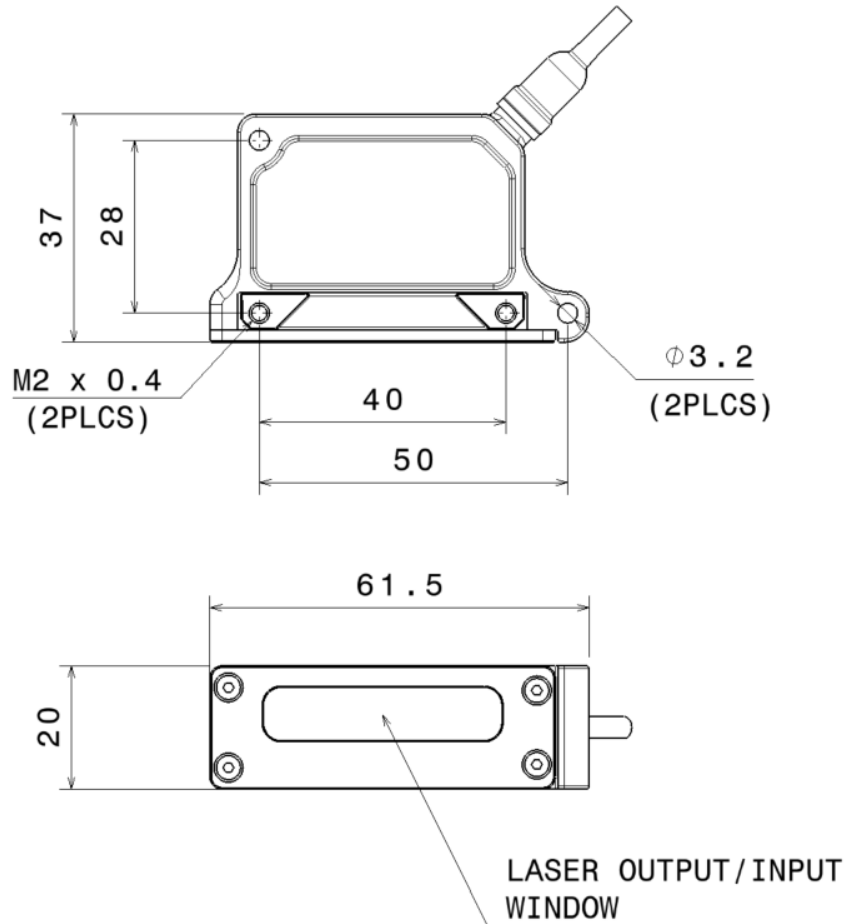

CONNECTION DETAILS

+Ve Supply	0V/GND	Analogue Output	CAN (Hi)	CAN (Lo)
Yellow	Green	White	Red	Blue

kasensors.com
sales@kasensors.com

RHL5 05.24
KA009D-DS

Sensors
For
Motorsport

OUTPUT GRAPH

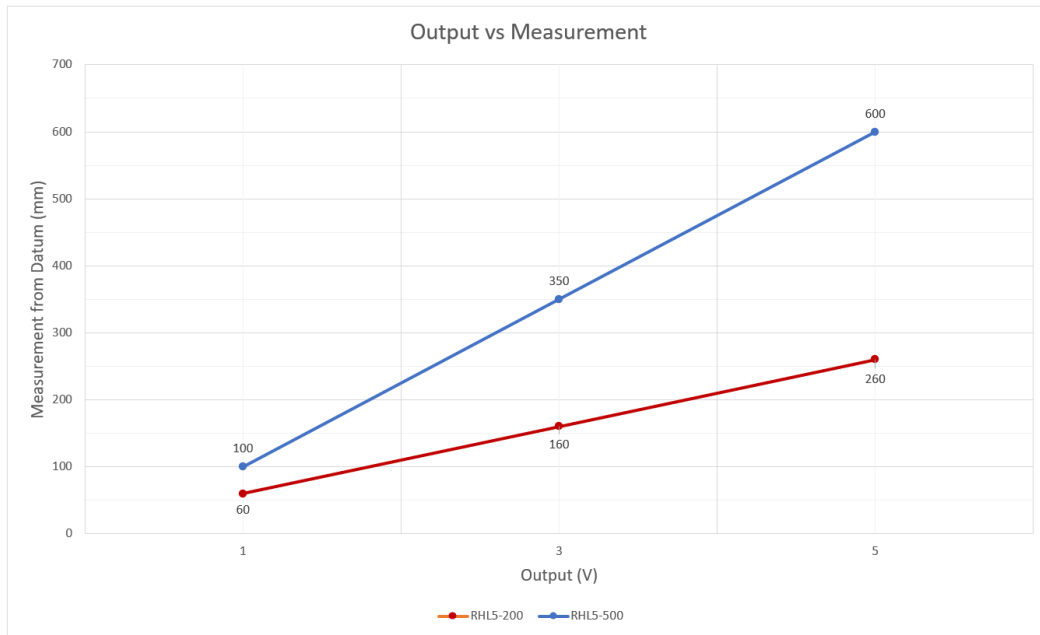

CAN CONFIGURATION (KEY FEATURES)

Parameter	Options	Description
Measurement Rate	250Hz	Measurement rate of the sensor, ranging from 250Hz up to 4000Hz
	500Hz	
	1000Hz	
	2000Hz	
	4000Hz	
Measurement Averaging	None	No averaging
	Moving	Moving average, with a depth of: 2, 4, 8, 16, 32, 64 and 128.
	Recursive	Recursive average, with a depth of 2 to 32767
	Median	Median average, with a depth of 3, 5, 7 and 9
Error Handling (Outhold)	None	No error handling
	Infinite	Infinite holding of the last in-range measurement value
	<n>	Hold the last in-range measurement value for a defined number of cycles (1 to 1024)
Region of Interest (ROI)	Start <n>	Specify a specific region of interest within the measurement range, <n> is defined as the percentage of the total range.
	End <n>	
CAN Interface		
CAN Type	High Speed (ISO 11898-2)	
Baud	Fixed 1 Mbps	
Termination Resistor	None	

Further details regarding the CAN setup/configuration can be found within the dbc (provided at request).

Sensors
For
Motorsport

kasensors.com
sales@kasensors.com

RHL5 05.24
KA009D-DS