



## GSS SERIES GEAR SHIFT LOAD CELL

The GSS Series of Miniature Load Cells are designed for the detection and measurement of tension and compression forces in Gear Shift Application.

Construction is stainless steel with a built-in amplifier, allowing for a very simple installation with only a 3 wire connection needed. Mechanical mounting is via M6 or M8 threads.

The output signal is proportional to the amount of force applied and is linear 0.5 to 4.5V which can be connected to most common ECU's. The typical application is for use such as: Flat Shift, Quickshifter, Torque Cut, Ignition Cut and Clutch-free Gearshift on race vehicles.

The Load Cells are generally installed into the actuator rod or cable on sequential gearboxes.

## TECHNICAL SPECIFICATIONS

Range	±500N, ±1000N or ±2000N
Safe Over Range	150% of Range
Accuracy	±1% FS Combined Linearity & Hysteresis (CNLH)
Thermal Effects	Zero ±0.01% FS/°C (Sensitivity ±0.01% of Reading /°C)
Output	0.5V to 4.5V (2.5v Offset, ±0.5%) +V in Compression
Supply	5V (±0.5V) Ratiometric or 8-16V
Operating Temperature Range	-20°C to +125°C
Compensated Temperature Range	0°C to +125°C
Construction	Stainless Steel and Aluminium
Electrical Connection	100cm, 55Spec, 26AWG Cable + DR25 Sleeve
Thread Size	M6 x 1 or M8 x 1.25 (Left Hand/Right Hand)
Protection Class	IP67. Dust & water tight. Immersion to 1m for 30mins
Weight	30g—40g, Dependant on Thread Size (Excluding Cable)

KA Sensors adopts a continuous development program which sometimes necessitates specification changes without notice.

PRESSURE | TEMPERATURE | FORCE | TORQUE | POSITION | SPEED | ACCELERATION | GYRO

*Sense  
Analyse  
Control*

### Features

- ±500N to ±2000N
- Miniature Size
- 5V or 8-16V Supply
- IP67 Sealed
- ±1% Accuracy
- Rugged Construction

### Applications

- Gear Shift
- Suspension
- Steering
- Pedal Force
- Aero Struts
- General Testing

bf1systems.com

sales@kasensors.com

GSS  
KA019F-DS (rev1)

# PART NUMBER CONFIGURATOR

Range

**GSS** - [ ] - [ ] - [ ] - [ ] - [ ]

±500N 0500  
 ±1000N 1000  
 ±2000N 2000

Supply

5V Ratiometric 4  
 8-16V 5

Thread Length / Type

Female/Female (M6 x 1 Thread Only) F  
 Long Male/Male (LH/RH) L  
 Short Male/Male (LH/RH) S

Thread Size

M6 x 1 6  
 M8 x 1.25 8

Special Code

None 000

*Sense  
 Analyse  
 Control*

Services for:

- Data Logging
- Telemetry
- Controls
- Wiring

# MECHANICAL DETAILS

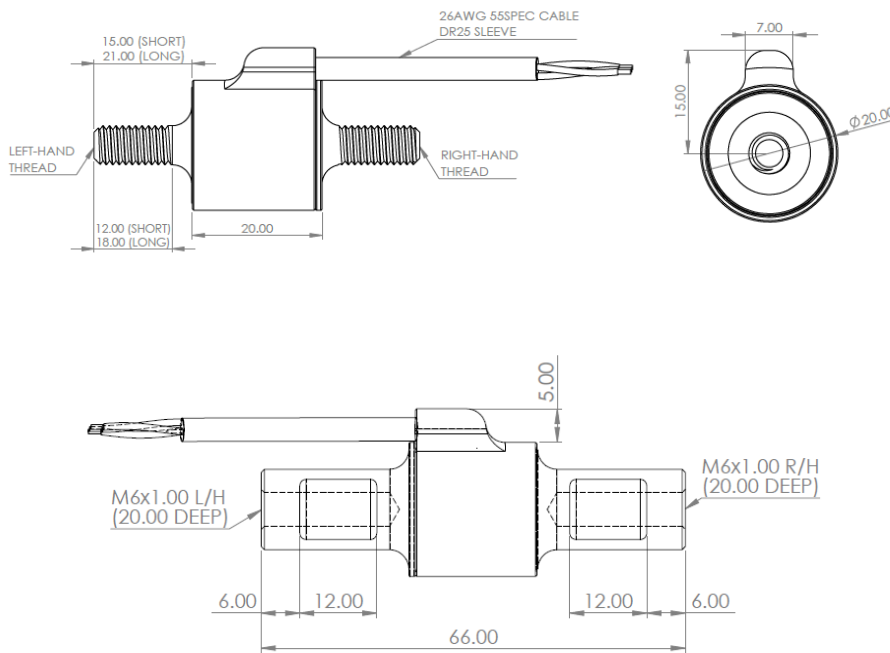

# CONNECTION DETAILS

+Ve Supply	0V Supply	Signal
Red	Black	White

## Contact us

KA Sensors Ltd  
 Unit 13, Priest Court  
 Springfield Business Park  
 Grantham  
 United Kingdom  
 NG31 7FZ

bf1systems.com  
 sales@kasensors.com

GSS  
 KA019F-DS (rev1)